

Adjustable weldable rail clip WM16R

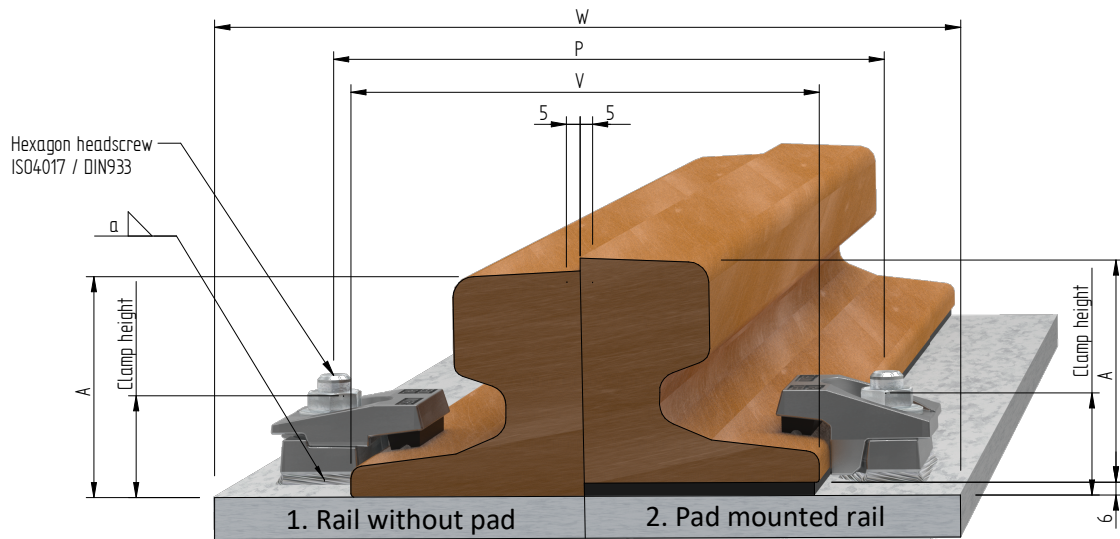

Clamp height
S = 37 [mm]
L = 43 [mm]

	Inside distance between baseplates			V	Rail base + 10	[mm]
	Distance between bolts M16			P	Rail base + 45	[mm]
	Minimum width sole plate			W	Rail base + 100	[mm]
	F [mm]	C [mm]	A [mm]	1. Rail without pad		2. Pad mounted rail
A45	125	45	55	WM16R S		WM16R L
A55	150	55	65	WM16R S		WM16R L
A65	175	65	75	WM16R S		WM16R L
A75	200	75	85	WM16R S		WM16R L
A100	200	100	95	WM16R S		WM16R L
MRS51	127	64	127	WM16R S		WM16R L
MRS67	132	76	146	WM16R S		WM16R L
QU70	120	70	120	WM16R S		WM16R L
QU80	130	80	130	WM16R S		WM16R L
QU100	150	100	150	WM16R S		WM16R L
QU120	170	120	170	WM16R S		WM16R L
S20	82	44	100	WM16R S		WM16R L
30E1 (S30)	108	60,3	108	WM16R S		WM16R L
33E1 (S33)	105	58	134	WM16R S		WM16R L
40E1 (S41-R14)	125	67	138	WM16R S		WM16R L
41E1 (S41-R10)	125	67	138	WM16R S		WM16R L
49E1 (S49)	125	67	149	WM16R S		WM16R L
S54	125	67	154	WM16R S		WM16R L
46E3 (NP46)	120	72	142	WM16R S		WM16R L
50E2 (EB50T)	140	67	151	WM16R S		WM16R L
EB63	140	72	151	WM16R S		WM16R L
54E1 (UIC54)	140	70	159	WM16R S		WM16R L
60E1 (UIC60)	150	72	172	WM16R S		WM16R L

Specification Bolts		Fillet weld	Max side load [kN]	
Hexagon headscrew:	ISO4017 / DIN933	a4	140 [kN]	
Steel grade:	8.8 HDG	a5	180 [kN]	
Tightening torque:	200 [Nm]			

Adjustable weldable rail clip WM16R L

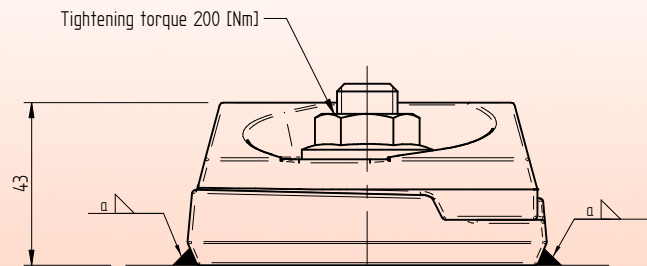
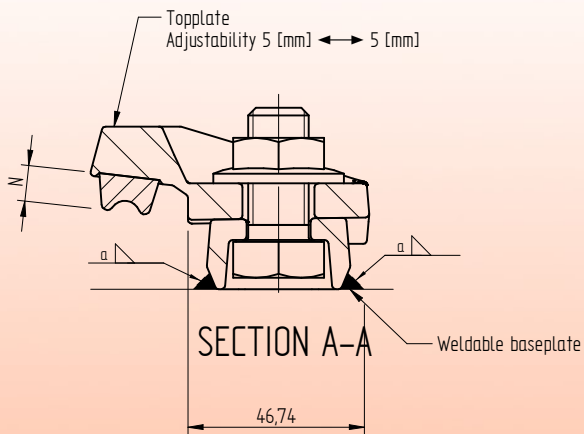
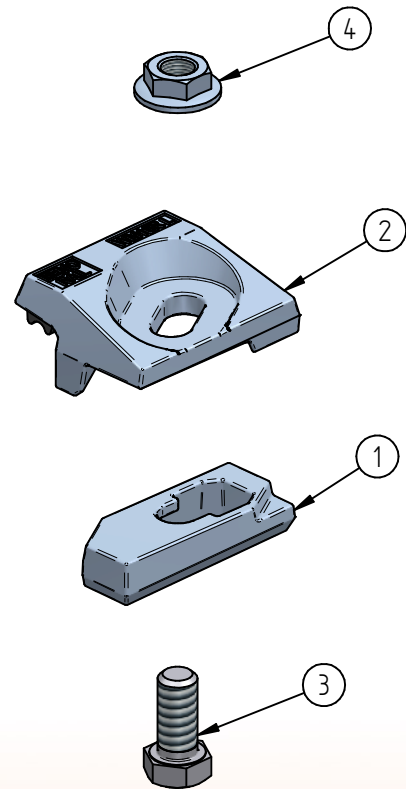
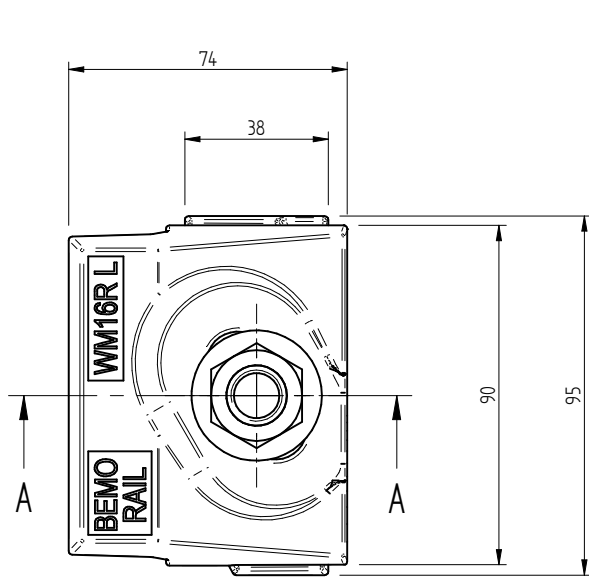

* Standard preservation is hot dip galvanized.
Other preservation options in agreement

Name	N
WM16C L N10	10,0 [mm]
WM16C L N12	12,0 [mm]
WM16C L N14	14,0 [mm]

4	Hexagon flange nut	Grade 8 H.D.G.	M16 ISO-metric	-	m = 0,044 [kg]
3	Hexagon head screw	8.8 HDG.	M16x35	DIN 933	m = 0,133 [kg]
2	Weldable adjustable rail clamp cover L with rubber nose	S355 J2*	WM16RC L		m = 0,605 [kg]
1	Adjustable rail clamp base	S355 J2 self coloured	WM16RB		m = 0,282 [kg]
Item	Description	Material	Type / Dimensions	Norm	Comments



BemoRail

Debbemeerweg 59
1749 DK Warmenhuizen
The Netherlands

Tel.: +31 (0)226 425300
Email: info@bemorail.nl
www.bemorail.com

Adjustable weldable rail clip WM16R S

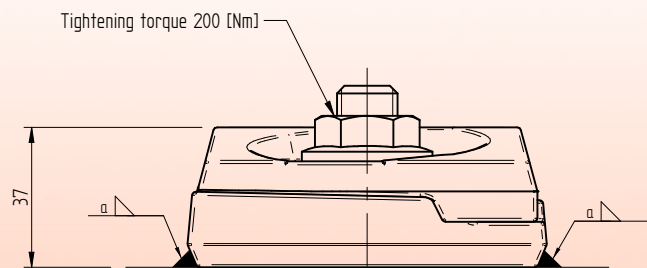
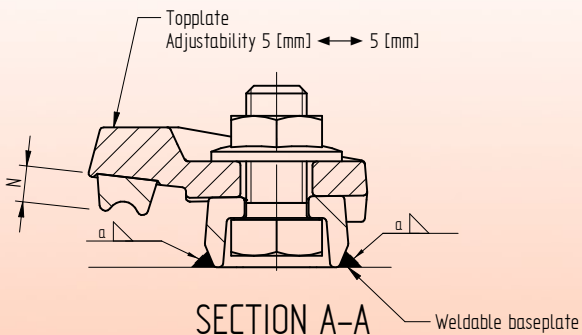
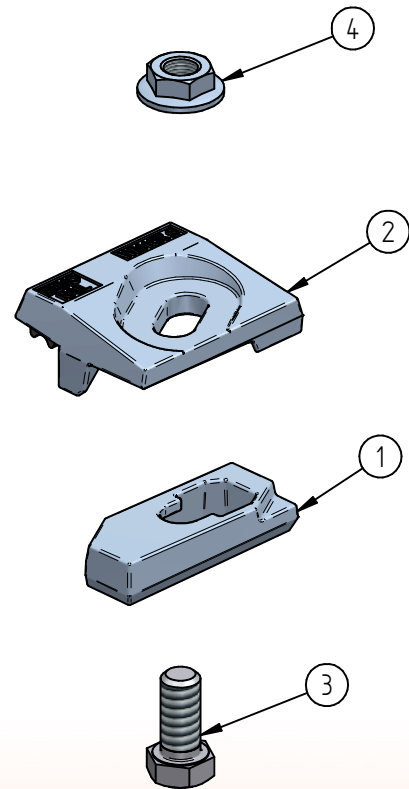
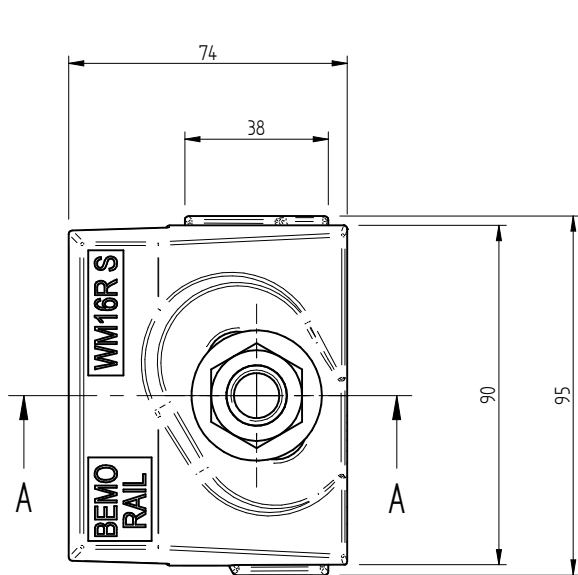

Name	N
WM16C S N10	10,0 [mm]
WM16C S N12	12,0 [mm]
WM16C S N14	14,0 [mm]

* Standard preservation is hot dip galvanized.
Other preservation options in agreement

4	Hexagon flange nut	Grade 8 H.D.G.	M16 ISO-metric	-	m = 0,044 [kg]
3	Hexagon head screw	8.8 HDG.	M16x35	DIN 933	m = 0,133 [kg]
2	Weldable adjustable rail clamp cover L with rubber nose	S355 J2*	WM16RC S		m = 0,590 [kg]
1	Adjustable rail clamp base	S355 J2 self coloured	WM16RB		m = 0,282 [kg]
Item	Description	Material	Type / Dimensions	Norm	Comments



BemoRail

Debbemeerweg 59
1749 DK Warmenhuizen
The Netherlands

Tel.: +31 (0)226 425300
Email: info@bemorail.nl
www.bemorail.com