

Adjustable weldable double rail clip STS20DR

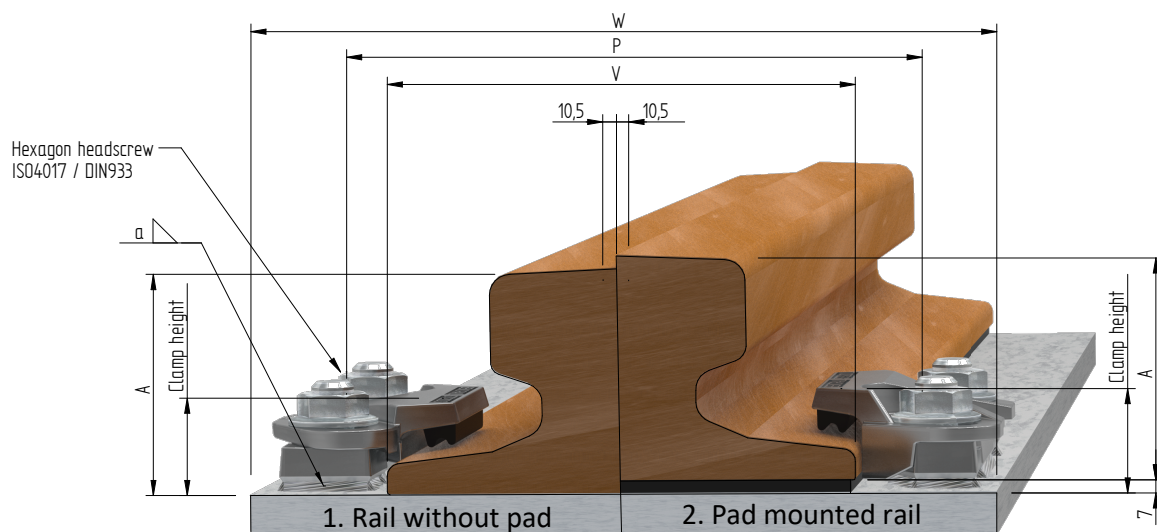

Clamp height	
S	= 38 [mm]
L	= 44 [mm]
XL	= 50 [mm]

	Inside distance between baseplates			V	Rail base + 21	[mm]
	Distance between bolts M20			P	Rail base + 69	[mm]
	Minimum width sole plate			W	Rail base + 127	[mm]
	F [mm]	C [mm]	A [mm]	1. Rail without pad		2. Pad mounted rail
A100	200	100	95	STS20DR S	STS20DR S	
A120	220	120	105	STS20DR S	STS20DR L	
A150	220	150	150	STS20DR S	STS20DR L	
AS86	150	101,6	152,4	STS20DR S	STS20DR L	
MRS51	127	64	127	STS20DR S	STS20DR L	
MRS67	132	76	146	STS20DR S	STS20DR L	
MRS87A	152,4	101,6	152,4	STS20DR S	STS20DR L	
PRI85r	152,4	101,6	152,4	STS20DR S	STS20DR L	
MRS125	180	120	180	STS20DR L	STS20DR XL	
BSC101	165	100	150	STS20DR S	STS20DR L	
ISCR70	120	70	120	STS20DR S	STS20DR L	
ISCR80	130	80	130	STS20DR S	STS20DR L	
ISCR100	150	100	150	STS20DR S	STS20DR L	
ISCR120	170	120	170	STS20DR S	STS20DR L	
ISCR140	170	140	170	STS20DR L	STS20DR XL	
QU70	120	70	120	STS20DR S	STS20DR L	
QU80	130	80	130	STS20DR S	STS20DR L	
QU100	150	100	150	STS20DR S	STS20DR L	
QU120	170	120	170	STS20DR S	STS20DR L	
S54	125	67	154	STS20DR S	STS20DR L	
50E2 (EB50T)	140	67	151	STS20DR S	STS20DR L	
EB63	140	72	151	STS20DR S	STS20DR L	

Specification Bolts	Fillet weld	Max side load [kN]	
Hexagon headscrew: ISO4017 / DIN933	a4	180 [kN]	
Steel grade: 8.8 HDG	a5	230 [kN]	
Tightening torque: 300 [Nm]	a6	270 [kN]	

Adjustable weldable double rail clip STS20DR S

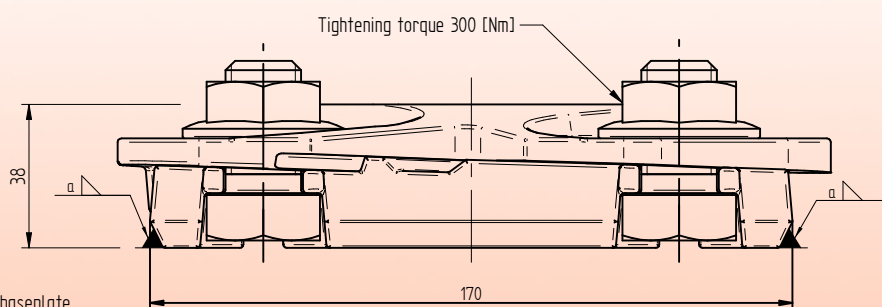
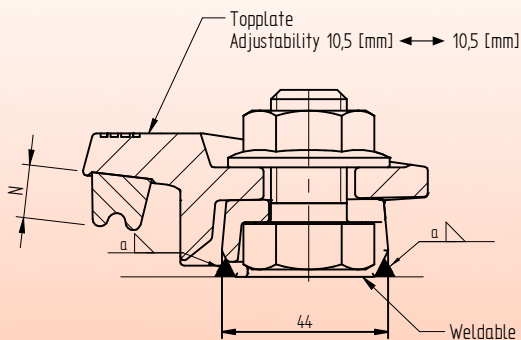
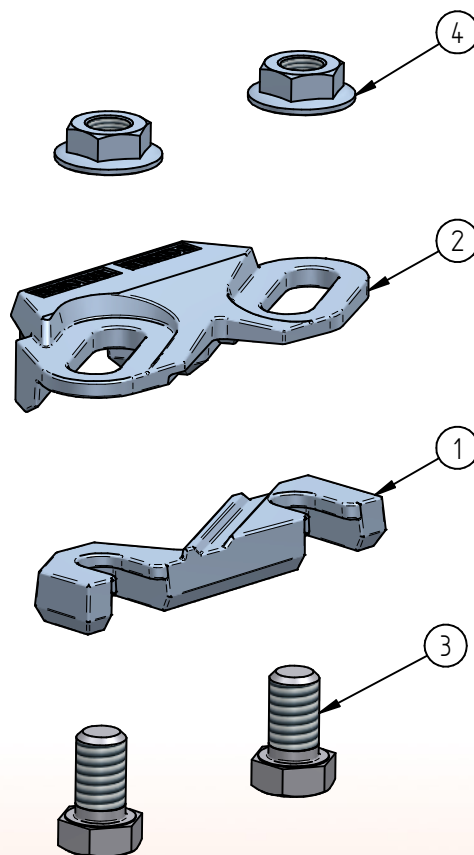
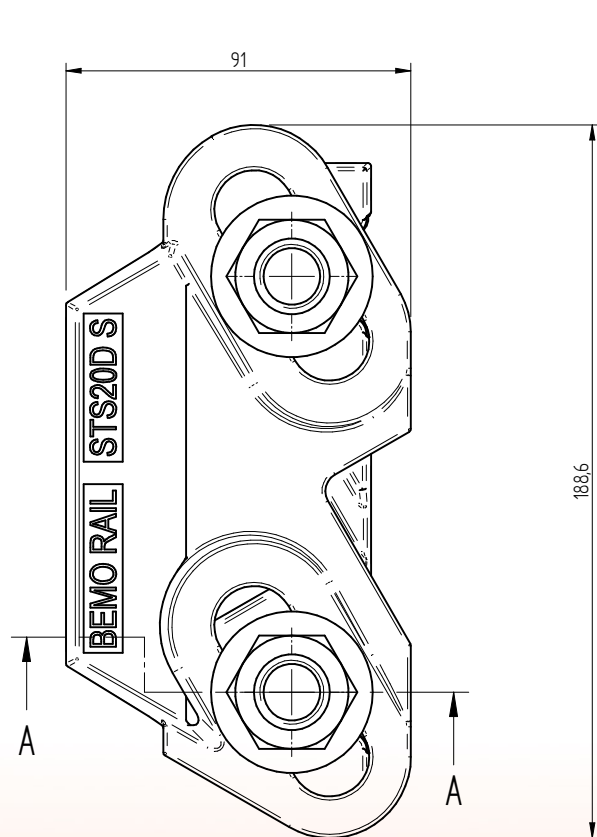

SECTION A-A

Name	N
STS20DRC S N9	9,0 [mm]
STS20DRC S N11	11,0 [mm]
STS20DRC S N13	13,0 [mm]

* Standard preservation is hot dip galvanized.
Other preservation options in agreement

4	Low hexagon flange nut	Grade 8 HDG.	M20 ISO-metric	-	m = 0,059 [kg]
3	Hexagon head screw	8.8 ZP.	M20x35	DIN 933	
2	Weldable adjustable rail clamp cover S with rubber nose 10	S355J2*	STS20DC S		m = 1,137 [kg]
1	Weldable adjustable rail clamp base	S355J2 self coloured	STS20DB		m = 0,600 [kg]
Item	Description	Material	Type / Dimensions	Norm	Comments



BemoRail

Debbemeerweg 59
1749 DK Warmenhuizen
The Netherlands

Tel.: +31 (0)226 425300
Email: info@bemorail.nl
www.bemorail.com

Adjustable weldable double rail clip STS20DR L

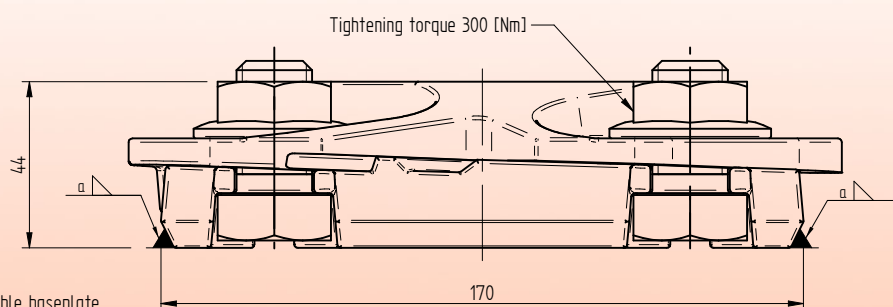
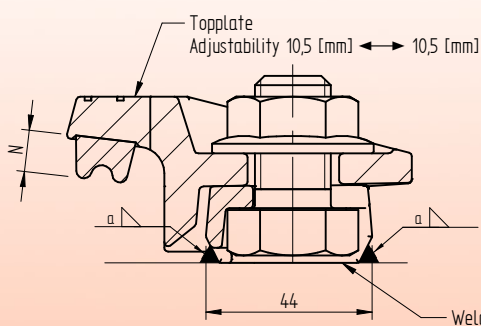
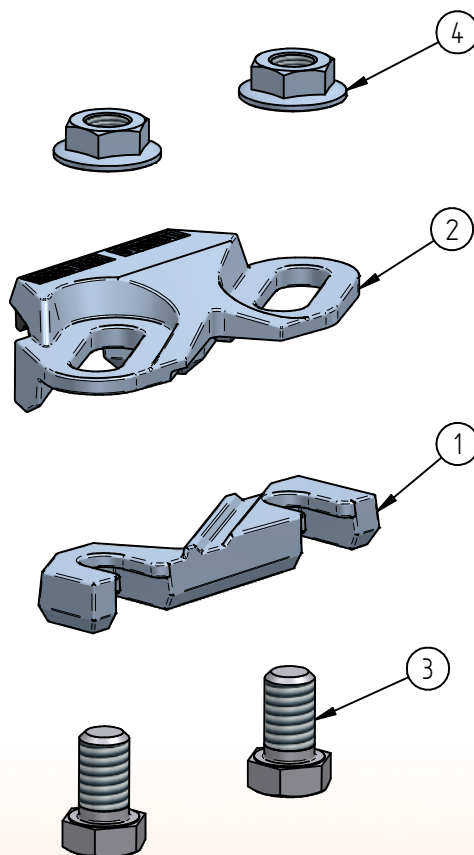
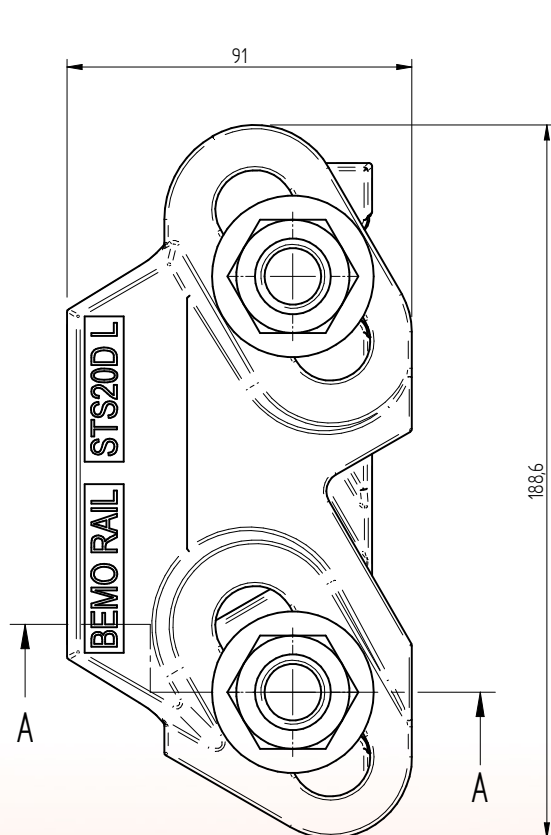

SECTION A-A

* Standard preservation is hot dip galvanized.
Other preservation options in agreement

Name	N
STS20DRC L N9	9,0 [mm]
STS20DRC L N11	11,0 [mm]
STS20DRC L N13	13,0 [mm]

4	Low hexagon flange nut	Grade 8 HDG.	M20 ISO-metric	-	m = 0,059 [kg]
3	Hexagon head screw	8.8 ZP.	M20x35	DIN 933	m = 0,160 [kg]
2	Weldable adjustable rail clamp cover L with rubber nose 11	S355J2 HDG	STS20DRC L N11		m = 1,221 [kg]
1	Weldable adjustable rail clamp base	S355J2 self coloured	STS20DB		m = 0,600 [kg]
Item	Description	Material	Type / Dimensions	Norm	Comments

Adjustable weldable double rail clip STS20DR XL

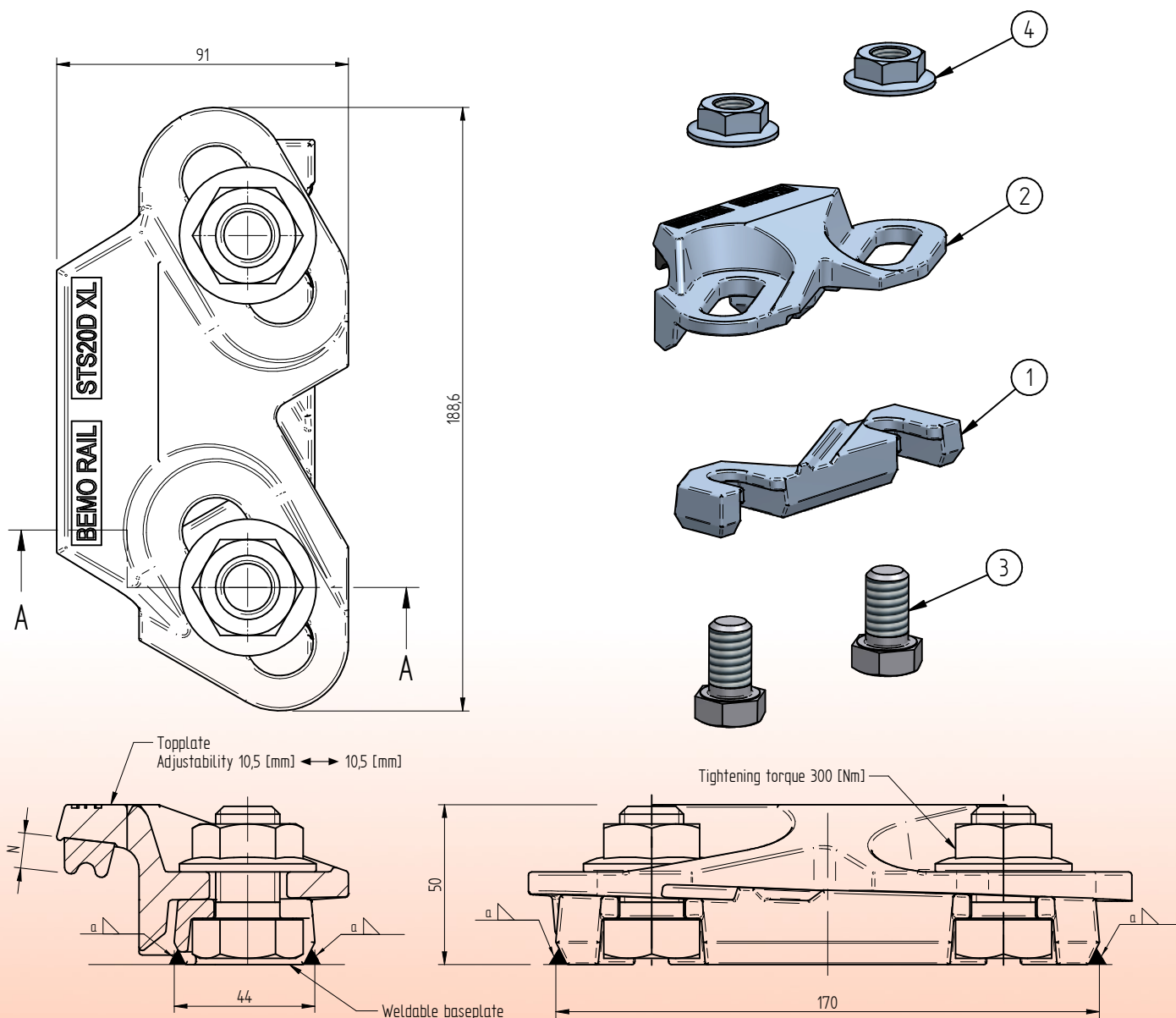

SECTION A-A

Name	N
STS20DRC XL N9	9,0 [mm]
STS20DRC XL N11	11,0 [mm]
STS20DRC XL N13	13,0 [mm]

* Standard preservation is hot dip galvanized.
Other preservation options in agreement

4	Low hexagon flange nut	Grade 8 HDG.	M20 ISO-metric	-	m = 0,059 [kg]
3	Hexagon head screw	8.8 ZP.	M20x35	DIN 933	
2	Weldable adjustable rail clamp cover L	S355J2*	STS20DC XL		m = 1,288 [kg]
1	Weldable adjustable rail clamp base	S355J2 self coloured	STS20DB		m = 0,600 [kg]
Item	Description	Material	Type / Dimensions	Norm	Comments



BemoRail

Debbemeerweg 59
1749 DK Warmenhuizen
The Netherlands

Tel.: +31 (0)226 425300
Email: info@bemorail.nl
www.bemorail.com