

Standard rail clip FM20

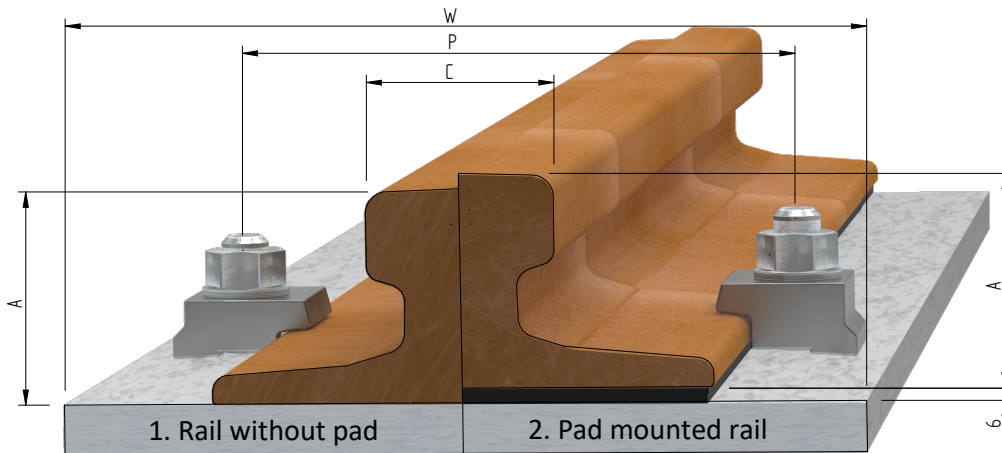

	Distance between stud M20			P	Rail base + 36	[mm]
	Minimum assembly width clips			W	Rail base + 90	[mm]
	Nominal width sole plate with anchorbolts			W	Rail base + 120	[mm]
	F [mm]	C [mm]	A [mm]	1. Rail without pad		2. Pad mounted rail
A55	150	55	65	FM20 H22		FM20 H28
A65	175	65	75	FM20 H22		FM20 H28
A75	200	75	85	FM20 H25		FM20 H31
A100	200	100	95	FM20 H25		FM20 H31
A120	220	120	105	FM20 H25		FM20 H31
AS86	150	101,6	152,4	FM20 H31		FM20 H37
PRI85r	152,4	101,6	152,4	FM20 H31		FM20 H37
MRS51	127	64	127	FM20 H28		FM20 H34
MRS67	132	76	146	FM20 H25		FM20 H31
MRS73	146	70	157	FM20 H31		FM20 H37
MRS87A	152,4	101,6	152,4	FM20 H31		FM20 H37
BSC101	165	100	155	FM20 H31		FM20 H37
ISCR70	120	70	120	FM20 H25		FM20 H31
ISCR80	130	80	130	FM20 H25		FM20 H31
ISCR100	150	100	150	FM20 H25		FM20 H31
ISCR120	170	120	170	FM20 H28		FM20 H34
QU70	120	70	120	FM20 H25		FM20 H31
QU80	130	80	130	FM20 H25		FM20 H31
QU100	150	100	150	FM20 H25		FM20 H31
QU120	170	120	170	FM20 H28		FM20 H34
30E1 (S30)	108	60	108	FM20 H22		FM20 H28
33E1 (S33)	105	58	134	FM20 H22		FM20 H28
40E1 (S41-R14)	125	67	138	FM20 H22		FM20 H28
41E1 (S41-R10)	125	67	138	FM20 H22		FM20 H28
49E1 (S49)	125	67	149	FM20 H25		FM20 H31
S54	125	67	154	FM20 H25		FM20 H31
46E3 (NP46)	120	72	142	FM20 H25		FM20 H31
50E2 (EB50T)	140	67	151	FM20 H25		FM20 H31
EB63	140	72	151	FM20 H28		FM20 H34
54E1 (UIC54)	140	70	159	FM20 H25		FM20 H31
60E1 (UIC60)	150	72	172	FM20 H25		FM20 H31
ASCE85	131,8	65,1	131,8	FM20 H22		FM20 H28

Specification	Stud bolt M20 DIN938 Grade 8.8 HDG	
Maximum side load without Fv	75 [kN]	
Tightening torque	300 [Nm]	

Standard rail clip FM20 H22

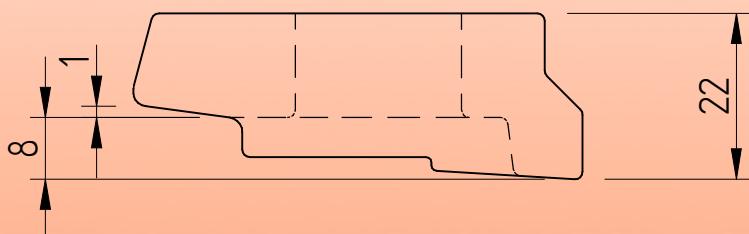
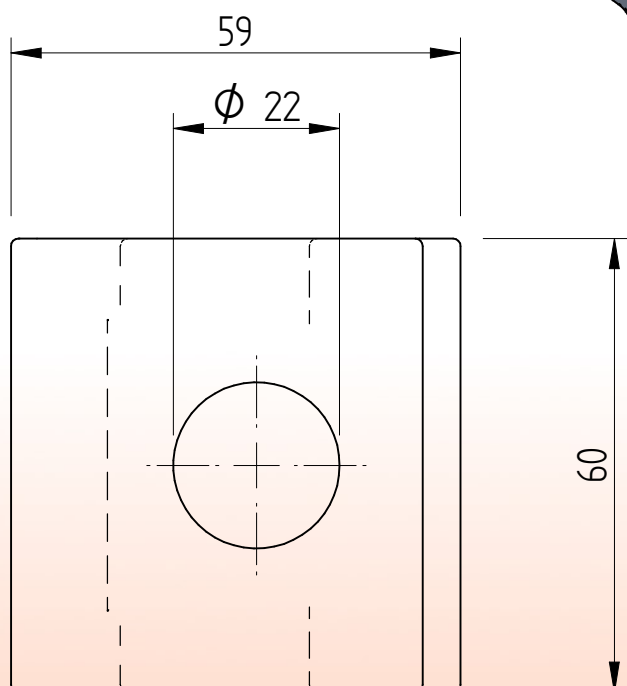
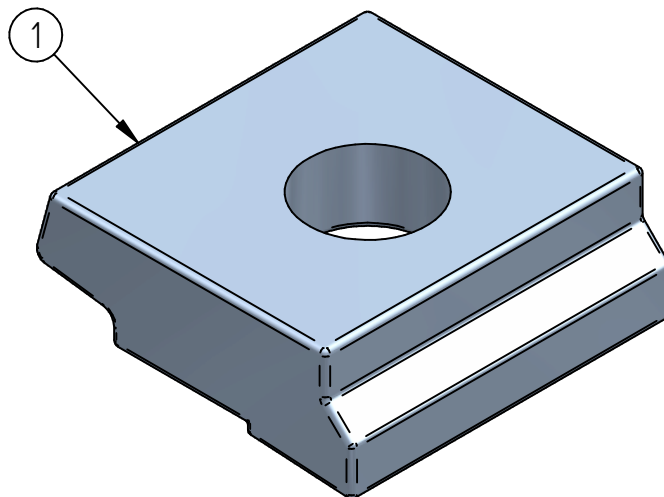

Item	Description	Material	Type / Dimensions	Norm	Comments
1	Railclip FM20	S235JR H.D.G.	FM20 H22		m = 0,384 [kg]



BemoRail

Debbemeerweg 59
1749 DK Warmenhuizen
The Netherlands

Tel.: +31 (0)226 425300
Email: info@bemorail.nl
www.bemorail.com

Standard rail clip FM20 H25

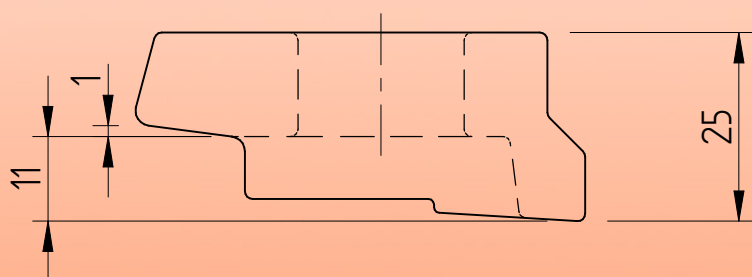
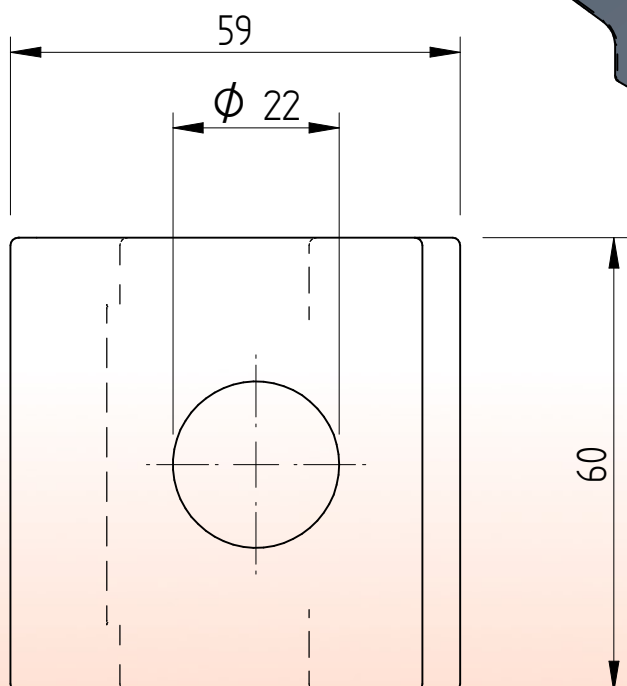
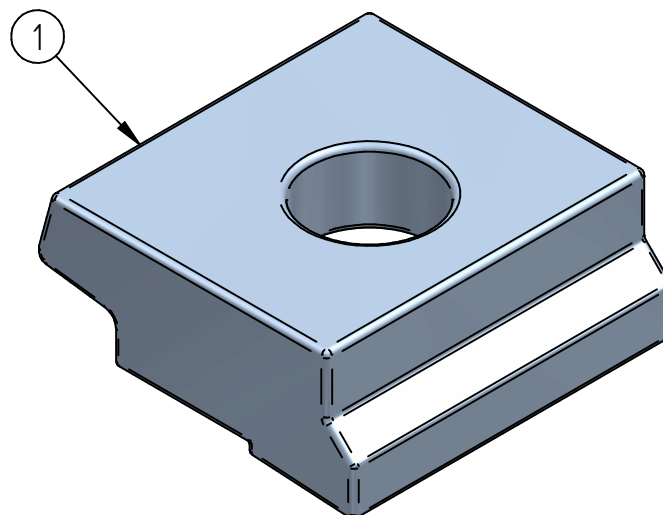

Item	Description	Material	Type / Dimensions	Norm	Comments
1	Railclip FM20	S235JR H.D.G	FM20 H25		m = 0,410 [kg]



BemoRail

Debbemeerweg 59
1749 DK Warmenhuizen
The Netherlands

Tel.: +31 (0)226 425300
Email: info@bemorail.nl
www.bemorail.com

Standard rail clip FM20 H28

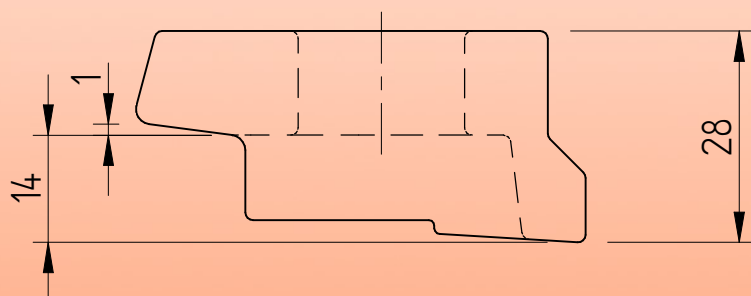
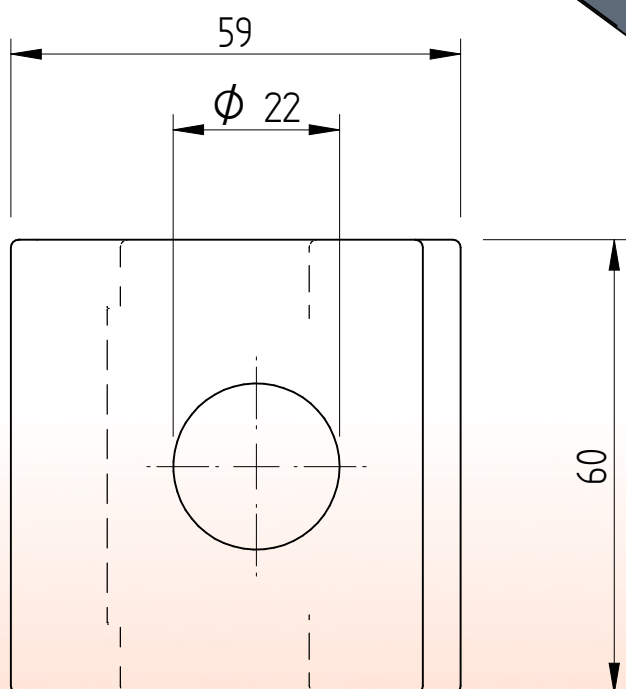
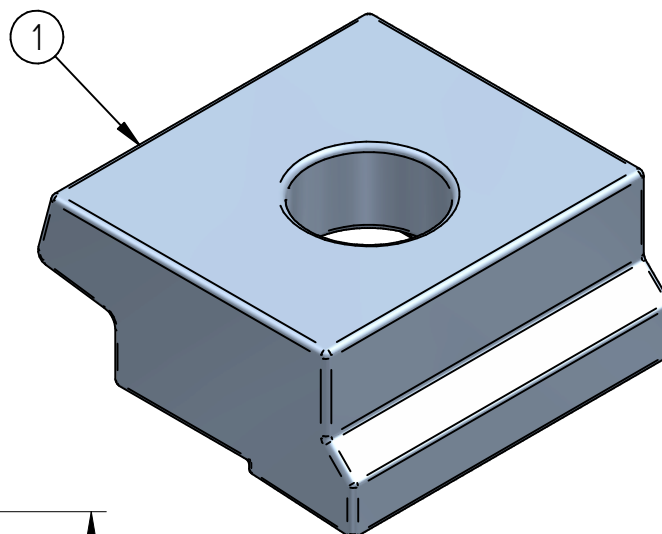

Item	Description	Material	Type / Dimensions	Norm	Comments
1	Railclip FM20	S235JR H.D.G	FM20 H28		m = 0,436 [kg]



BemoRail

Debbemeerweg 59
1749 DK Warmenhuizen
The Netherlands

Tel.: +31 (0)226 425300
Email: info@bemorail.nl
www.bemorail.com

Standard rail clip FM20 H31

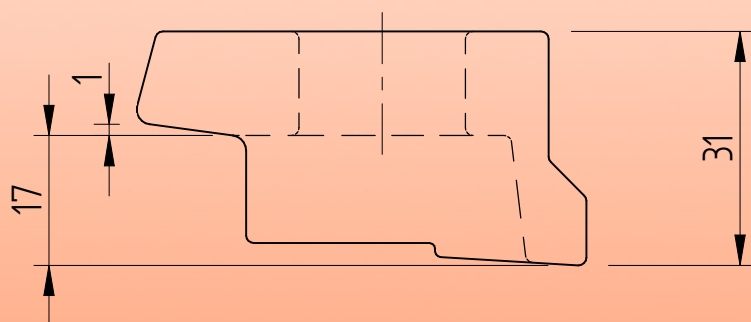
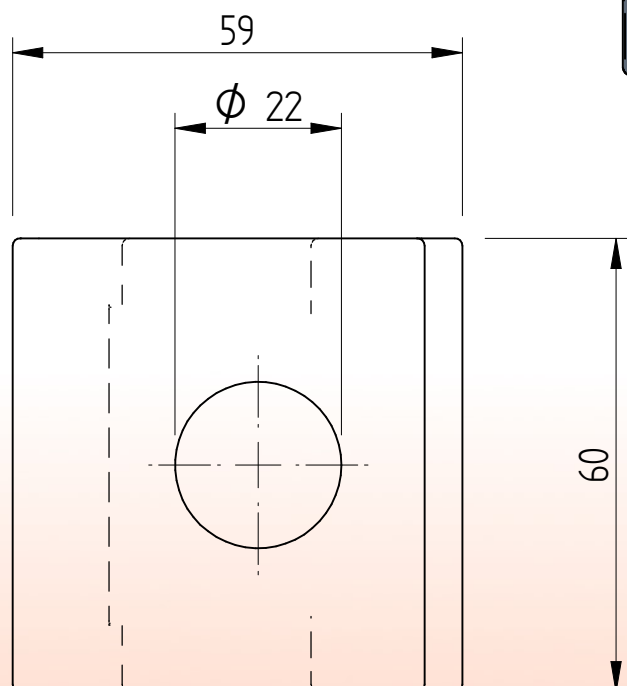
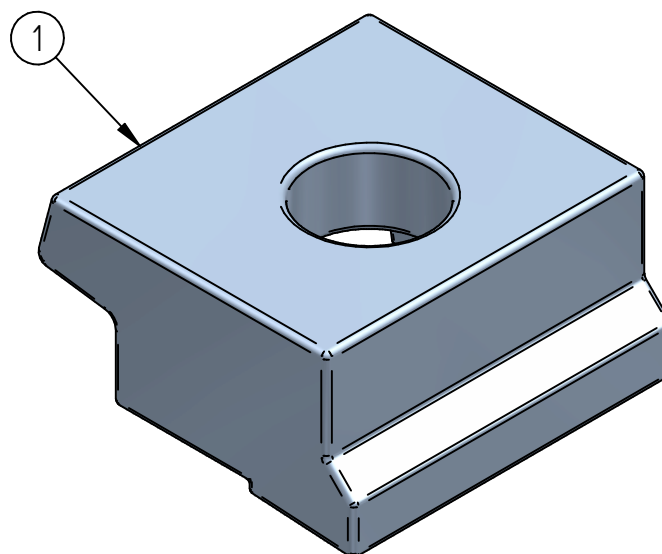

Item	Description	Material	Type / Dimensions	Norm	Comments
1	Railclip FM20	S235JR H.D.G.	FM20 H31		m = 0,458 [kg]



BemoRail

Debbemeerweg 59
1749 DK Warmenhuizen
The Netherlands

Tel.: +31 (0)226 425300
Email: info@bemorail.nl
www.bemorail.com

Standard rail clip FM20 H34

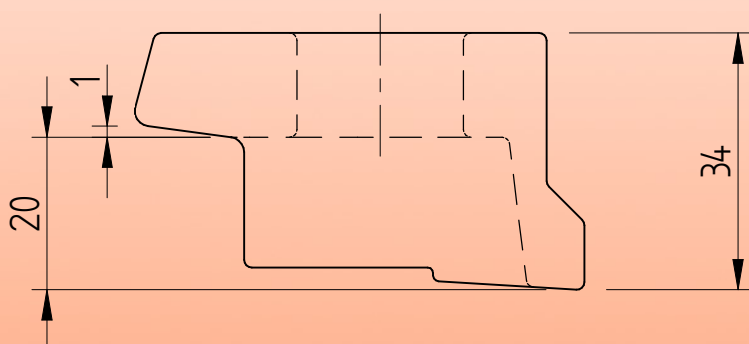
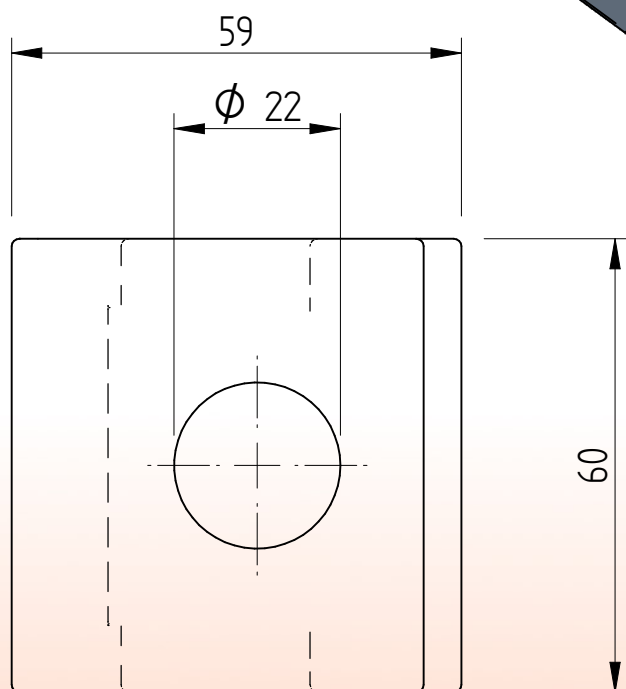
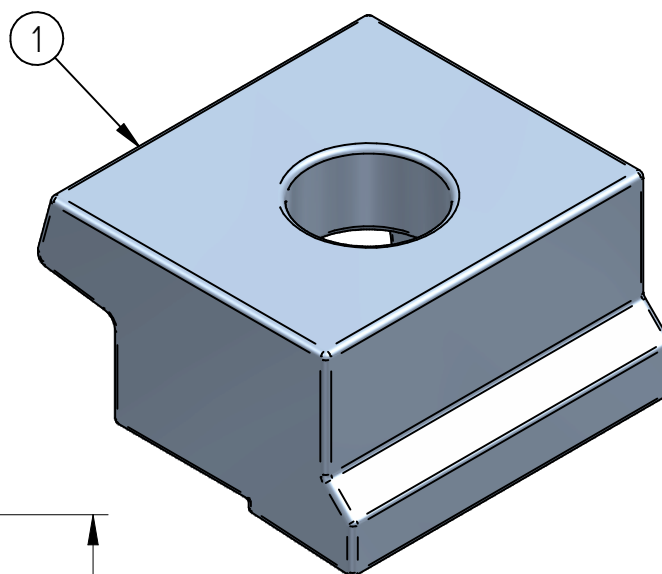

Item	Description	Material	Type / Dimensions	Norm	Comments
1	Railclip FM20	S235JR H.D.G.	FM20 H34		m = 0,481 [kg]



BemoRail

Debbemeerweg 59
1749 DK Warmenhuizen
The Netherlands

Tel.: +31 (0)226 425300
Email: info@bemorail.nl
www.bemorail.com

Standard rail clip FM20 H37

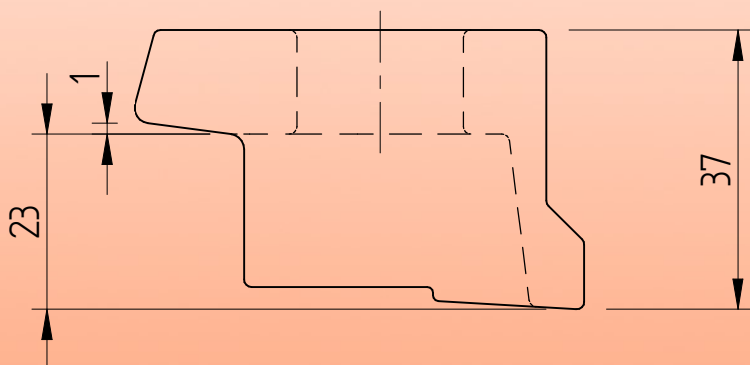
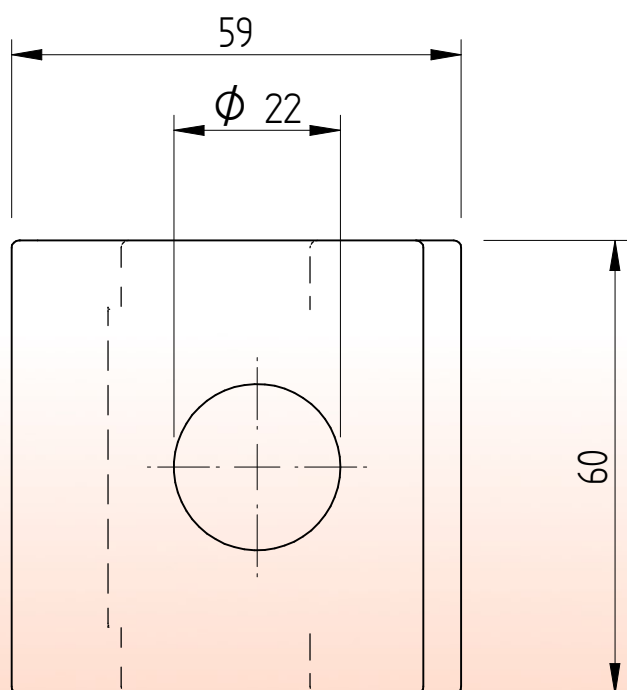
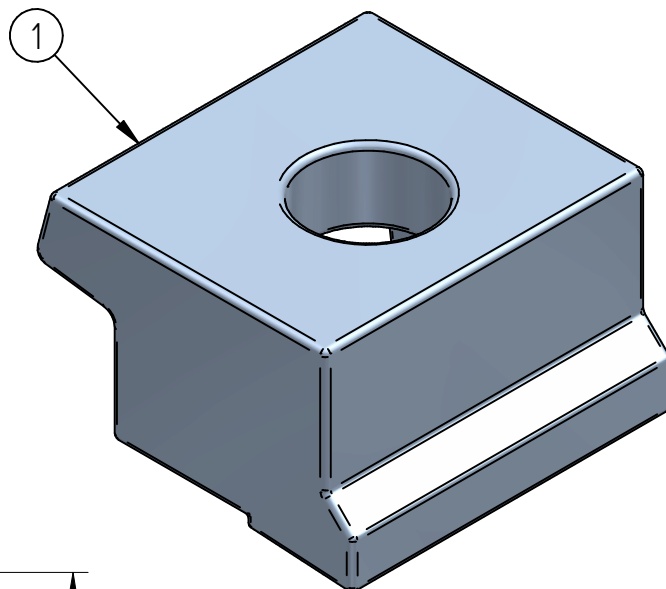

Item	Description	Material	Type / Dimensions	Norm	Comments
1	Railclip FM20	S235JR H.D.G.	FM20 H37		m = 0,503 [kg]



BemoRail

Debbemeerweg 59
1749 DK Warmenhuizen
The Netherlands

Tel.: +31 (0)226 425300
Email: info@bemorail.nl
www.bemorail.com

Standard rail clip FM20

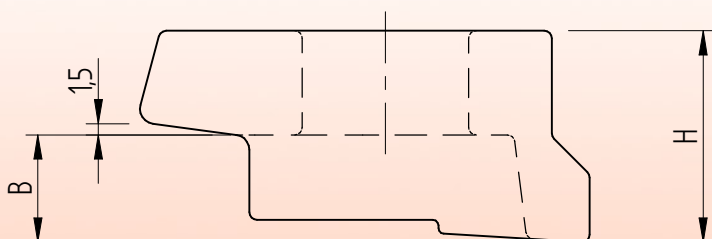
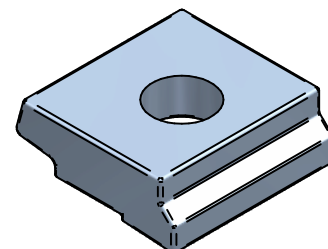
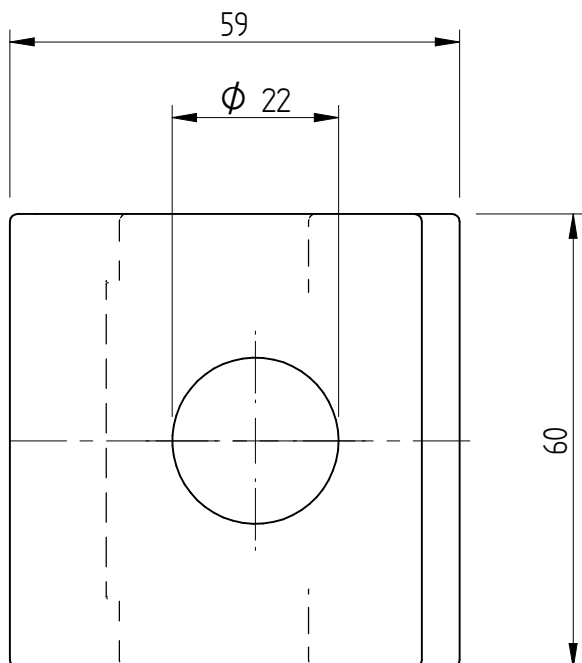

Name	B	H	Mass
FM20 H22	8,0 [mm]	22,0 [mm]	0,384 [kg]
FM20 H25	11,0 [mm]	25,0 [mm]	0,410 [kg]
FM20 H28	14,0 [mm]	28,0 [mm]	0,436 [kg]
FM20 H31	17,0 [mm]	31,0 [mm]	0,458 [kg]
FM20 H34	20,0 [mm]	34,0 [mm]	0,481 [kg]
FM20 H37	23,0 [mm]	37,0 [mm]	0,503 [kg]

* Standard preservation is hot dip galvanized
Other preservation options in agreement

Item	Description	Material	Type / Dimensions	Norm	Comments
1	Railclip FM20		Type nr	DIN -	Fabrikant



BemoRail

Debbemeerweg 59
1749 DK Warmenhuizen
The Netherlands

Tel.: +31 (0)226 425300
Email: info@bemorail.nl
www.bemorail.com