

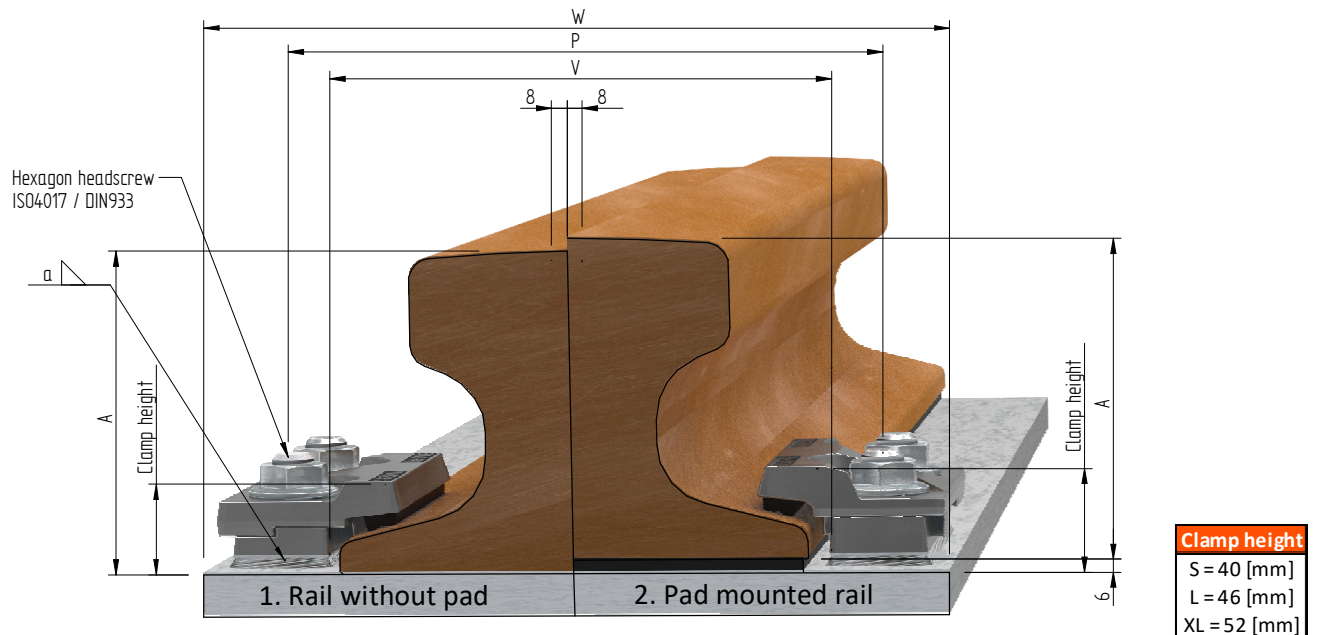

Adjustable weldable double rail clip WDM20R



	Inside distance between baseplates			V	Rail base + 16	[mm]
	Distance between bolts M20			P	Rail base + 62	[mm]
	Minimum width sole plate			W	Rail base + 126	[mm]
	F [mm]	C [mm]	A [mm]	1. Rail without pad		2. Pad mounted rail
A75	200	75	85	WDM20R S		WDM20R L
A100	200	100	95	WDM20R S		WDM20R L
A120	220	120	105	WDM20R S		WDM20R L
A150	220	150	150	WDM20R S		WDM20R L
AS86	150	101,6	152,4	WDM20R L		WDM20R XL
MRS51	127	64	127	WDM20R S		WDM20R L
MRS67	132	76	146	WDM20R S		WDM20R L
MRS87A	152,4	101,6	152,4	WDM20R L		WDM20R XL
PRI85r	152,4	101,6	152,4	WDM20R L		WDM20R XL
MRS125	180	120	180	WDM20R L		WDM20R XL
BSC101	165	100	150	WDM20R L		WDM20R XL
ISCR70	120	70	120	WDM20R S		WDM20R L
ISCR80	130	80	130	WDM20R S		WDM20R L
ISCR100	150	100	150	WDM20R S		WDM20R L
ISCR120	170	120	170	WDM20R S		WDM20R L
ISCR140	170	140	170	WDM20R L		WDM20R XL
QU70	120	70	120	WDM20R S		WDM20R L
QU80	130	80	130	WDM20R S		WDM20R L
QU100	150	100	150	WDM20R S		WDM20R L
QU120	170	120	170	WDM20R S		WDM20R L
49E1 (S49)	125	67	149	WDM20R S		WDM20R L
S54	125	67	154	WDM20R S		WDM20R L
46E3 (NP46)	120	72	142	WDM20R S		WDM20R L
50E2 (EB50T)	140	67	151	WDM20R S		WDM20R L
EB63	140	72	151	WDM20R S		WDM20R L
54E1 (UIC54)	140	70	159	WDM20R S		WDM20R L
60E1 (UIC60)	150	72	172	WDM20R S		WDM20R L

Specification Bolts		Fillet weld	Max side load [kN]
Hexagon headscrew:	ISO4017 / DIN933	a4	230 [kN]
Steel grade:	8.8 HDG	a5	290 [kN]
Tightening torque:	300 [Nm]		



Adjustable weldable double rail clip WDM20R S

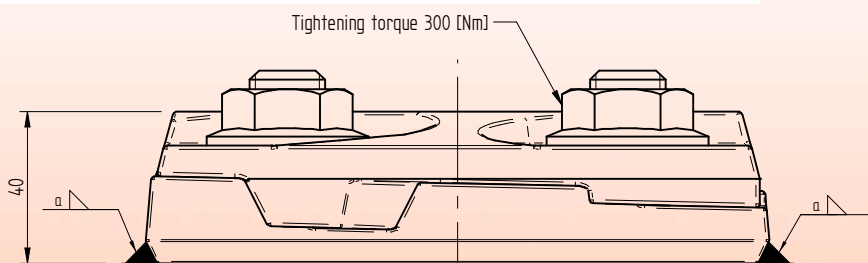
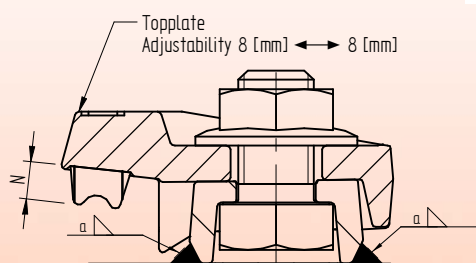
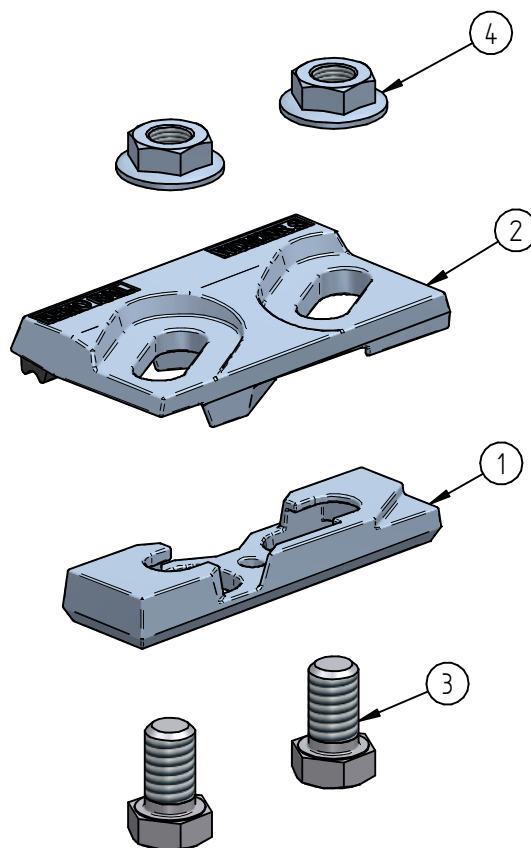
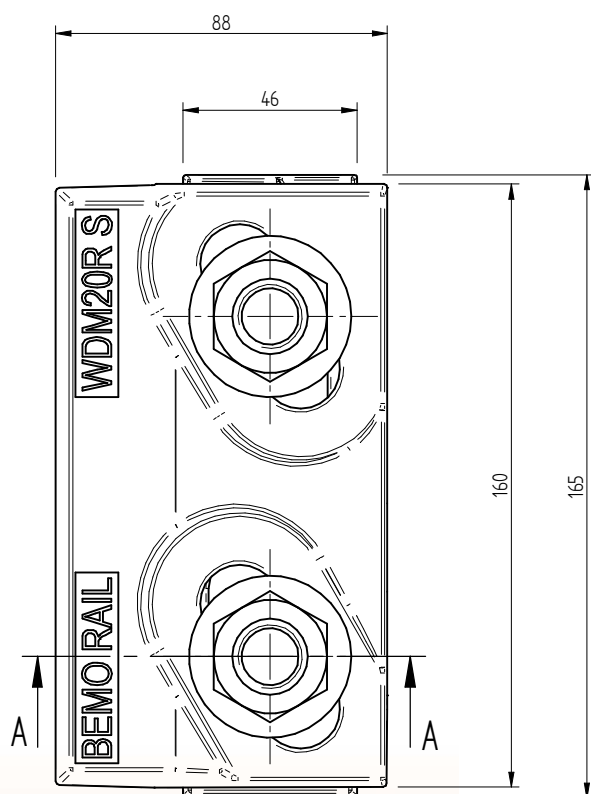

SECTION A-A — Weldable baseplate

Name	N
WDM20R S N10	10,0 [mm]
WDM20R S N12	12,0 [mm]
WDM20R S N14	14,0 [mm]

* Standard preservation is hot dip galvanized.
Other preservation options in agreement

4	Low hexagon flange nut	Grade 8 HDG.	M20 ISO-metric	-	m = 0,082 [kg]
3	Hexagon head screw	8.8 HDG.	M20x35	DIN 933	m = 0,161 [kg]
2	Weldable adjustable rail clamp cover S with rubber nose	S355J2*	WDM20RC S		m = 1,407 [kg]
1	Weldable adjustable rail clamp base	S355J2 self coloured	WDM20RB		m = 0,524 [kg]
Item	Description	Material	Type / Dimensions	Norm	Comments

Adjustable weldable double rail clip WDM20R L

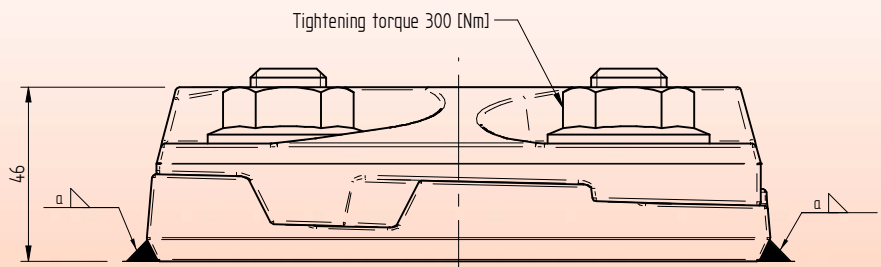
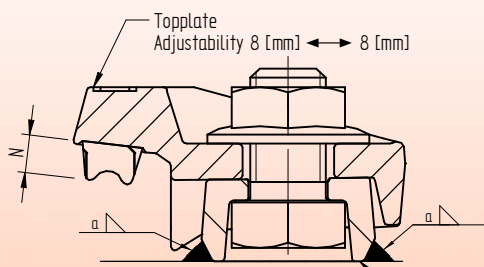
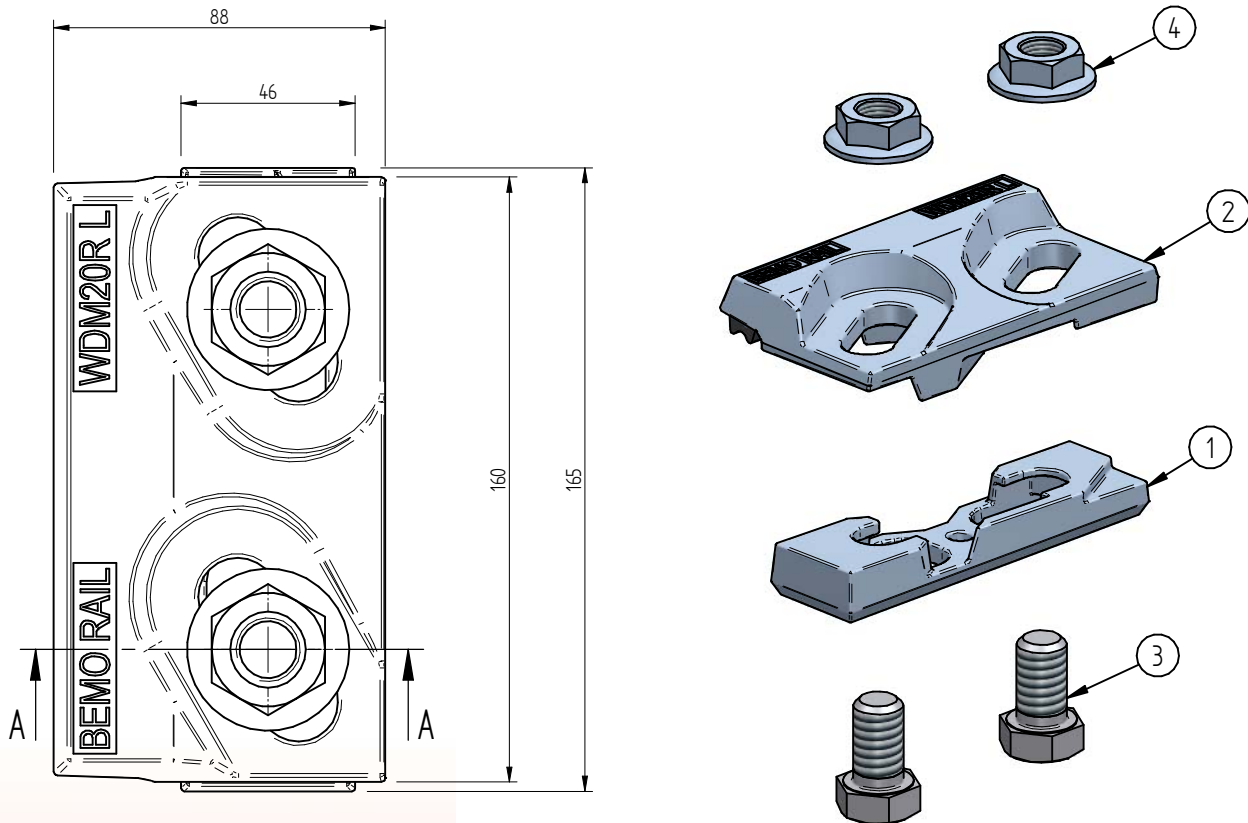

SECTION A-A — Weldable baseplate

* Standard preservation is hot dip galvanized.
Other preservation options in agreement

Name	N
WDM20R L N10	10,0 [mm]
WDM20R L N12	12,0 [mm]
WDM20R L N14	14,0 [mm]

4	Low hexagon flange nut	Grade 8 HDG.	M20 ISO-metric	-	m = 0,082 [kg]
3	Hexagon head screw	8.8 HDG.	M20x35	DIN 933	m = 0,161 [kg]
2	Weldable adjustable rail clamp cover L with rubber nose	S355J2*	WDM20RC L		m = 1,471 [kg]
1	Weldable adjustable rail clamp base	S355J2 self coloured	WDM20RB		m = 0,524 [kg]
Item	Description	Material	Type / Dimensions	Norm	Comments

Adjustable weldable double rail clip WDM20R XL

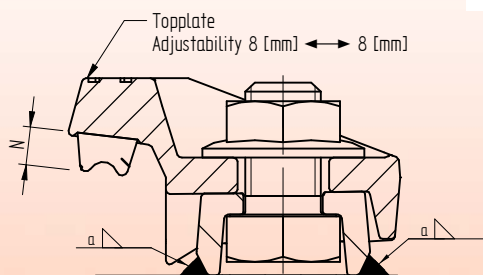
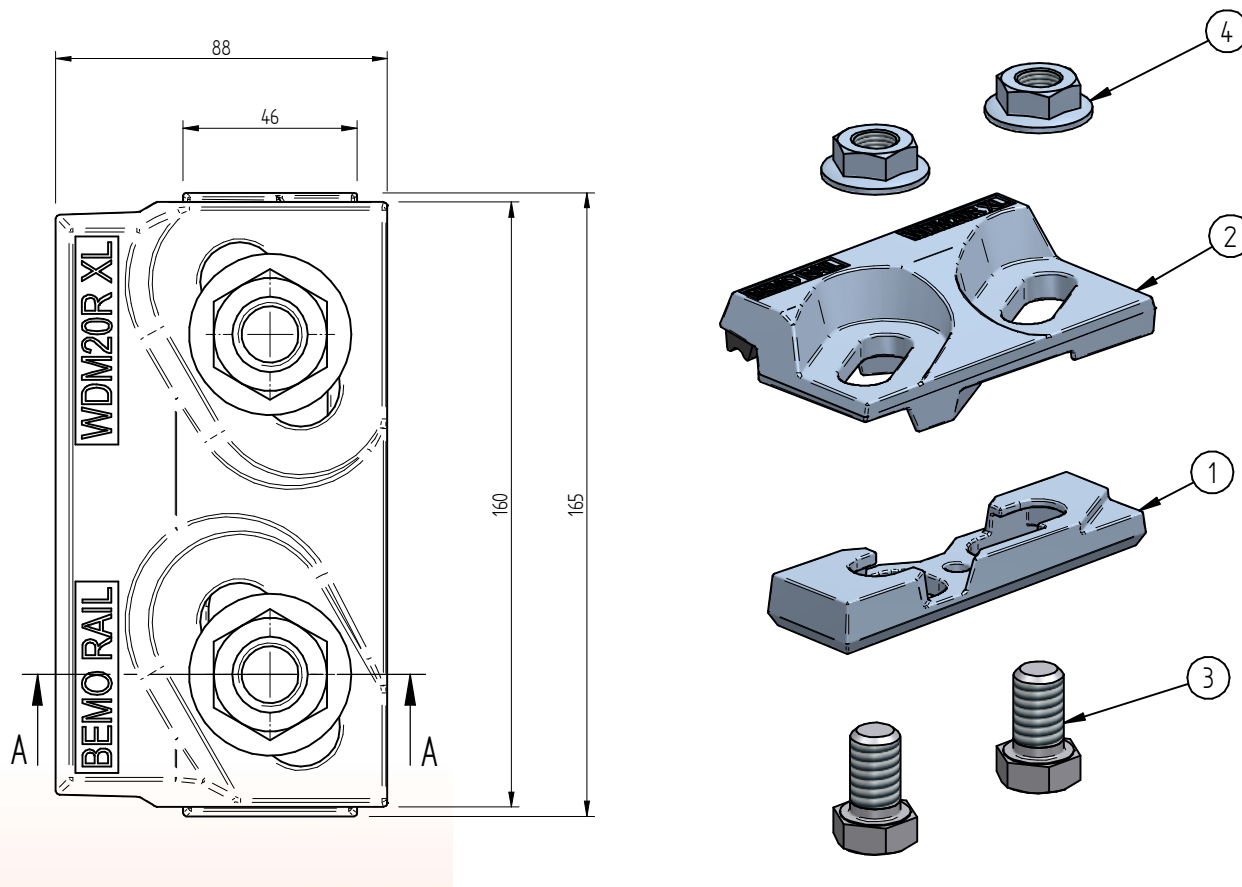

SECTION A-A — Weldable baseplate

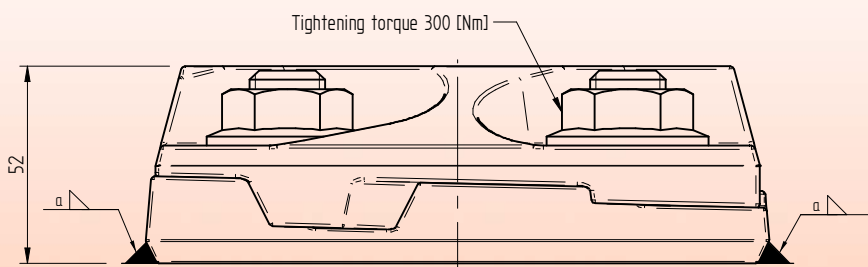

* Standard preservation is hot dip galvanized.
Other preservation options in agreement

Name	N
WDM20R XL N10	10,0 [mm]
WDM20R XL N12	12,0 [mm]
WDM20R XL N14	14,0 [mm]

4	Low hexagon flange nut	Grade 8 HDG.	M20 ISO-metric	-	m = 0,082 [kg]
3	Hexagon head screw	8.8 HDG.	M20x35	DIN 933	m = 0,161 [kg]
2	Weldable adjustable rail clamp cover XL with rubber nose	S355J2*	WDM20RC XL		m = 1,512 [kg]
1	Weldable adjustable rail clamp base	S355J2 self coloured	WDM20RB		m = 0,524 [kg]
Item	Description	Material	Type / Dimensions	Norm	Comments



BemoRail

Debbemeerweg 59
1749 DK Warmenhuizen
The Netherlands

Tel.: +31 (0)226 425300
Email: info@bemorail.nl
www.bemorail.com